

DATA SHEET.

EL-SC/LB2 | eLume LB2 LED Light Bar

Our easy to install eLume LB2 LED Light Bar provides a high brightness area of illumination for indoor architectural lighting applications. With precision manufacturing that ensures quality, resiliency and a lifespan of over 50,000 hours, a projection distance of up to 2.5 meters, our eLume LB2 LED Light Bars are ideal solution to achieving your desired, linear lighting effects.

SPECIFICATIONS.

MODEL # :	(A) EL-SC/LB2/480 (B) EL-SC/LB2/240
LENGTH OPTIONS :	(A) 495mm (19.5") (B) 255mm (10")
LED QTY :	(A) 72 x 3528 LEDs (B) 36 x 3528 LEDs
POWER CONSUMPTION :	(A) 7W (B) 3W
LUMEN OUTPUT @ 5500K :	(A) 347 lm (B) 198 lm
COLOUR TEMPERATURE :	Daylight White 5500K or Warm White 3200K
BEAM ANGLE :	120°
FINISH OPTIONS :	Brushed Aluminum or Satin Black
LENS OPTIONS :	Milky Diffused White or Clear
OPERATING VOLTAGE :	12VDC (SMPS INPUT : 90~240VAC, 50~60Hz)
LIFE SPAN :	≥ 50,000 hours
WARRANTY :	3 YEARS
POWER SUPPLY OPTIONS :	Information available upon request.

BENEFITS.

- Mounting clips allows for simple installation.
- Simple daisy chainable, plug and play installation.
- Extremely slim profile
- Zero maintenance.
- Even, bright illumination.
- Environmentally friendly.
- No special disposal requirements.
- Contains no hazardous material.
- Omits no UV radiation.
- Up to 2.5M projection distance
- 3 Year warranty

DIMENSIONS & INSTALL OPTIONS.

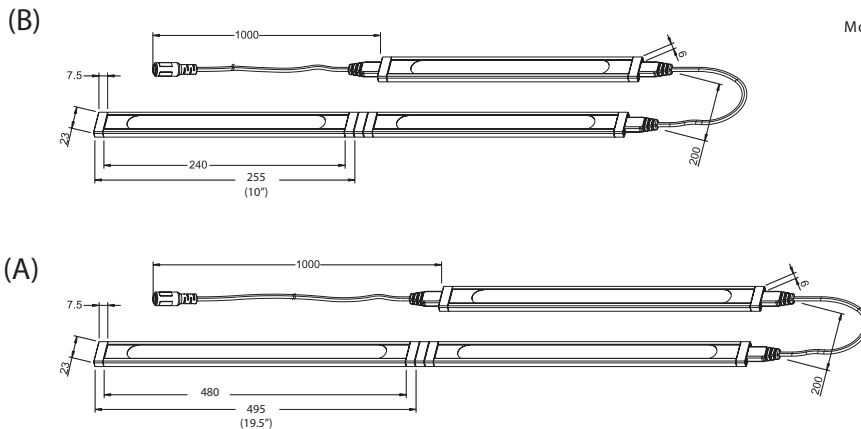

MOUNTING OPTIONS.

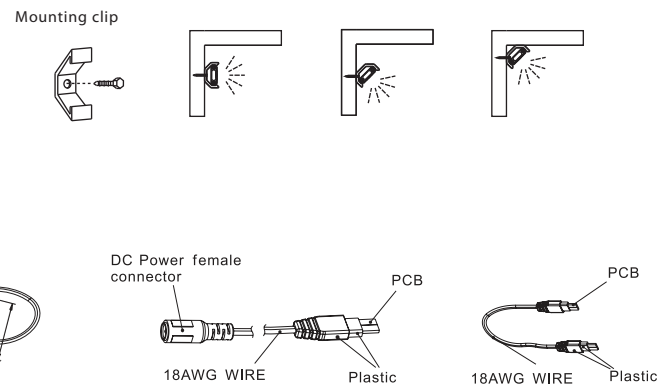

CONTACT INFO.

www.elumanation.com
T : 416.225.6400

info@elumanation.com
1621-3 McEwen Drive, Whitby ON.
Canada. L1N 9A5